

The Most Respected Name in Pilot Certification



ATP *Airline Pilot
Training &
Pilot Career
Development*
Airline Transport Professionals

Cessna 172

Training Supplement



Revised 2013-11-26

\$19.95

ATP FLIGHT SCHOOL.com
800-ALL-ATPS

800-255-2877 • 904-273-3018

IMPORTANT NOTICE

Refer to POH/AFM

Do not use procedures listed without referencing the full procedures described in the approved Owner's Manual, POH, or POH/AFM specific to the airplane you are flying. Endurance and fuel capacities may vary considerably depending on the specific model / serial number being flown and any modifications it may have.

Copyright © 2013 Airline Transport Professionals.

Configuration and throttle settings used throughout this manual are based on an 160 HP R-Model 172, which will vary depending on the specific airplane and prevailing conditions. Do not use procedures listed without referencing the full procedures described in the approved Operators Manual or POH/AFM specific to the airplane you are flying.

The content of this manual is furnished for informational use only, and is subject to change without notice. Airline Transport Professionals assumes no responsibility or liability for any errors or inaccuracies that may appear in this manual. This manual does not replace the Cessna 172 Pilot Operating Handbook, FAA Airplane Flying Handbook, or Practical Test Standards. Nothing in this manual shall be interpreted as a substitute for the exercise of sound judgement.

No part of this publication may be reproduced, stored in a retrieval system, or transmitted, in any form or by any means electronic, mechanical or otherwise, without the prior written permission of Airline Transport Professionals.

Contents

Early & Late Model Overview	1	No-Flap Approach & Landing	26
Inoperative Instruments & Equipment	2	Short-Field Approach & Landing	27
Aircraft Systems	3	Soft-Field Approach & Landing	28
Late Model (R&S)	3	Crosswind Approach & Landing	29
Early Model (K-P) Differences	6	Go-Around	31
GPS Setup	7	Missed Approach	31
Performance / Weight & Balance....	10	Rejected or Balked Landing.....	32
V-Speeds & Limitations	10	Precision Approach	33
Sample Weight & Balance Problem	11	Non-Precision Approach	34
Formulas	12	Circling Approach	34
CG Envelope Graph.....	12	In-Flight Maneuvers.....	35
Departure Procedures	13	Clean Configuration Flow.....	35
Normal Takeoff.....	13	Landing Configuration Flow	35
Short-Field Takeoff.....	14	Steep Turns	36
Soft-Field Takeoff	15	Maneuvering During Slow Flight	36
Engine Failure Procedure	16	Power-Off Stall	37
Arrival Procedures.....	17	Power-On Stall.....	37
Cessna 172 Landing Criteria.....	17	Emergency Descent	38
Good Planning = Good Landing.....	17	Chandelles.....	38
Approach Briefing – Verbalize the Plan	18	Lazy Eights.....	39
Stabilized Approach	18	Eights On Pylons.....	40
Aiming Point	19	Steep Spirals	41
Managing Energy	19	Accelerated Stall.....	41
Pitch & Power	19	Secondary Stall (Power-On).....	42
Go Around Philosophy	20	Secondary Stall (Power-Off)	42
Gust Factor.....	21	Elevator Trim Stall	43
Flap Setting	21	Cross-Control Stall.....	43
Seat Position	21	Oral Review	44
Traffic Pattern Operations	22	Lost Comm Procedure (FAR 91.185).....	44
Flaps 20° Approach & Landing	23	FAR Review	44
Flaps 10° Approach & Landing	25	Sample Oral Questions	45

Early & Late Model Overview

IMPORTANT: Aircraft information can be obtained from the Owner’s Manual, POH or POH-AFM (as appropriate for the model). Airplanes with engine modifications (and possibly increased gross weights) will have additional information in the Supplemental Airplane Flight Manual in Section 9. Refer to the official aircraft documents for ALL information.

ATP Cessna 172 aircraft models include R / S models (“Late Model”) and K thru P models (“Early Model”). Over 75% of ATP’s Cessna 172 fleet are Late Model.

R model Cessnas were introduced in 1996, and were the first to come factory equipped with fuel-injected engines. Starting procedures are substantially different between the earlier models with carbureted engines and the later models with injected engines. Review the engine start procedures by referencing the latest ATP 172 checklist for the 172 model you will be flying.

	<i>Model Number</i>	<i>Year of Production</i>
EARLY MODELS	172 K	1969–70
	172 L	1971–72
	172 M	1973–76
	172 N	1977–80
	172 P	1981–86
LATE MODELS	172 R	1996–2009
	172 S	1998–Present



NOTE: Some R Model aircraft have been modified with approved aircraft modifications. There is typically only one modification to the standard R model. This propeller modification, Cessna MK 172-72-01, provides for an increase in horsepower, which in turn increases fuel burn and maximum allowable takeoff weight.

ATP Cessna 172's have different combinations of engine horsepower and usable fuel. Some aircraft are equipped with only 38 gallons of useable fuel, and have been modified with a 180 horsepower engine. These airplanes have an increased fuel burn and a significantly reduced endurance of approximately 3 hours in the training environment – even with full tanks.

Calculate your fuel requirements carefully. Reference the aircraft manuals and placards for the appropriate information.

Airworthiness and Registration certificates can be found on the forward lower left interior cabin wall. Weight and balance information can be found in the logbook.

Inoperative Instruments & Equipment per FAR 91.213

ATP aircraft do not operate under the guidance of a minimum equipment list (MEL). ATP aircraft operate in accordance with the following FAR 91.213 subpart. Because this is only an excerpt, the complete subpart should be referenced if necessary:

- (3) The inoperative instruments and equipment are --
 - (i) Removed from the aircraft, the cockpit control placarded, and the maintenance recorded in accordance with §43.9 of this chapter; or
 - (ii) Deactivated and placarded "Inoperative." If deactivation of the inoperative instrument or equipment involves maintenance, it must be accomplished and recorded in accordance with part 43 of this chapter;
- (4) A determination is made by a pilot, who is certificated and appropriately rated under part 61 of this chapter, or by a person, who is certificated and appropriately rated to perform maintenance on the aircraft, that the inoperative instrument or equipment does not constitute a hazard to the aircraft.

Aircraft Systems

Late Model (R&S)

System descriptions are given first for Late Model, and then differences only for Early Model.

Engine

The 172 R and S models are equipped with a Lycoming, 4 cylinder, normally aspirated, fuel injected, 360 cubic inch, horizontally opposed, air cooled, direct drive IO-360-L2A engine. The R model produces 160 HP @ 2400 RPM, and the S model and R Model with Cessna 72-01 engine modification produces 180 HP @ 2700 RPM. Ignition is provided by 2 magnetos on the back of engine which provide spark to 8 spark plugs (2 per cylinder). The engine has an 8 quart oil sump. ATP minimum oil quantity for takeoff is 6 quarts.

Propeller

The engine drives a McCauley, 75 inch (R- Model) 76 inch (S- Model and R with Modification), 2 blade, all metal, fixed pitch propeller.

Vacuum System

Two engine-driven vacuum pumps are located on the back of engine, providing vacuum to the attitude and heading gyros, and have a normal operating range 4.5-5.5 inches of mercury. Failure of a vacuum pump is indicated by an annunciator panel light. In most circumstances, failure of one pump alone will not cause the loss of any instruments because the remaining pump should handle the entire vacuum demand.

Landing Gear

The landing gear is a fixed, tricycle type gear consisting of tubular spring steel providing shock absorption for the main wheels, and an oleo (air/oil) strut providing shock absorption on the nose wheel. The nose strut extends in flight, locking it in place. The nose wheel contains a shimmy damper which damps nose wheel vibrations during ground operations at high speeds. The nose wheel is linked to the rudder pedals by a spring loaded steering bungee which

turns the nose up to 10° each side of center. Differential braking allows for up to 30° of steering either side of center.

Brakes

Brakes are hydraulically actuated, main wheel single-disc brakes controlled by master cylinders attached to both pilots' rudder pedals. When the airplane is parked, the main wheel brakes may be set by the parking brake handle beneath the left side instrument panel. To apply the parking brake, set the brakes with the rudder pedals, pull the handle aft and rotate it 90° down.



NOTE: The parking brake is not to be used in training or flight checks with ATP.

Flaps

The 172 has single slot type flaps driven electrically by a motor in the right wing. A flap position selector on the instrument panel has detents at the 0°, 10°, 20° and 30° positions.

Pitot Static

The Pitot Static system consists of a pitot tube on left wing providing ram air pressure to the airspeed indicator, and a static port on the left side of the fuselage providing static pressure to the Altimeter, Vertical Speed Indicator and Airspeed Indicator. The pitot tube is electrically heated and an alternate static source is located under the instrument panel.

Fuel System

The fuel system consists of 2 tanks in the wings with a total fuel capacity of 56 gallons, of which 53 is usable. Usable fuel quantity is placarded on fuel selector. Typically there are 13 Fuel sumps – 5 each wing and 3 under engine cowling. There are 3 Fuel vents – 1 under left wing and 1 in each fuel cap.

Fuel is gravity fed from wing tanks to the fuel selector valve labeled BOTH, RIGHT, and LEFT, and then to a reservoir tank. From the reservoir tank the fuel flows to an electrically driven auxiliary fuel pump, past the fuel shutoff valve, through the strainer and to an engine driven fuel pump. Fuel is then delivered to the fuel air control unit where it is metered and passed to a manifold where it is distributed to each cylinder. The auxiliary fuel pump is used for engine priming during cold engine starts. The auxiliary fuel pump is OFF for normal takeoff and landing operations. **Review the manual.**



NOTE: The fuel selector should remain in BOTH during normal operations with ATP.

The injected engines do not have carburetor heat like early model engines. Alternate air is provided with a spring-loaded alternate air door in the air box. If the air induction filter should become blocked, suction created by the engine will open the door and draw unfiltered air from inside the lower cowl area. An open alternate air door will result in an approximately 10% power loss at full throttle.



NOTE: Do not over-prime fuel injected engines when conducting "warm" engine starts. Doing so washes away engine lubrication and causes cylinder wall damage.

Electrical System

The airplane is equipped with a 28 volt DC electrical system and a 24 volt 35 amp/hour battery. Electrical energy is supplied by a 60 amp alternator located on the front of the engine. An external power receptacle is located on the left side of engine cowl. Electrical power is distributed through electrical buses and circuit breakers. If an electrical problem arises, always check circuit breakers. "Essential" circuit breakers should be reset in flight only once, and only if there is no smoke or "burning smell", and only if the affected system and equipment is needed for the operational environment. Do not reset any non-essential circuit breakers in flight.

Exterior Lighting

Exterior lighting consists of navigation lights on the wing tips and top of the rudder, a dual landing (inboard) / taxi (outboard) light configuration located on the left wing leading edge, a flashing beacon mounted on the top of the vertical fin, and a strobe light on each wing tip.

Environmental

Cabin heat is provided by air ducted through the exhaust shroud and into the cabin and is controlled by a knob on the instrument panel. Air flow is controlled by a Cabin Air knob on the instrument panel and additionally by ventilators near the top corners of both left and right windshields.

Stall Warning

A pneumatic type stall warning system consists of an inlet on the left wing leading edge, which is ducted to a horn near the top left of the windshield. As the aircraft approaches a stall, the lower pressure on top of the wing shifts forward drawing air through horn resulting in an audible warning at 5 to 10 knots above the stall.

Early Model (K-P) Differences

Early model Cessnas are generally characterized by their pre-1996 production date and carbureted engines.

Engine

The unmodified early model 172's are equipped with a 320 cubic inch, O-320-E2D engine. The engine produces 150 HP @ 2700 RPM. Several of the early model 172's have been modified with approved aircraft modifications. Modified engines can have up to 180 HP, increased fuel burn, and significantly reduced endurance. There are typically two modifications to the early models.

These are:

Penn Yan – Replacement engine with higher horsepower, which increases fuel burn and max allowable takeoff weight.

Air Planes – Replacement engine with higher horsepower, which increases fuel burn and max allowable takeoff weight.

Vacuum System

The system has 1 vacuum pump.

Flaps

Some early models have no detents for flap settings, and some have up to 40 degrees of flaps.

Fuel System

The fuel system has a total usable fuel capacity of as little as 38 gallons (usable fuel is placarded on fuel selector). Typically there are 3 fuel sumps (1 each wing and 1 under engine cowling). There is no electrically driven auxiliary fuel pump. There is no separate fuel shutoff valve. In lieu of a separate fuel shutoff valve, the fuel selector valve has an OFF position. Fuel is delivered to a carburetor.

Electrical System

The airplane is equipped with a 14 volt DC electrical system and a 12 volt 25 amp/hour battery.

External Lighting

A single or dual landing/taxi light configuration is located at the front of the engine cowl.

Carburetor Heat

Under certain moist atmospheric conditions at temperatures of 20° to 70° F (-5° to 20° C), it is possible for ice to form in the induction system, even in summer weather. This is due to the high air velocity through the carburetor venturi and the absorption of heat from this air by vaporization of the fuel. To avoid this, the carburetor heat is provided to replace the heat lost by vaporization. The initial signs of carburetor ice can include engine roughness and a drop in engine RPM. Operated by the knob next to the throttle control, carburetor heat should be selected on if carburetor ice is expected or encountered. Adjust mixture for maximum smoothness.

GPS Setup

Benedix/King KLN94

Enroute

GPS: Moving Map page (Nav 4) - AUTO range mode.

Nav Source Selector Switch: Appropriate nav source.



Navigation Source Selector Switch



KLN94 Map Page

Full Panel Approaches

GPS: Moving Map page (Nav 4).

Nav Source Selector Switch: Appropriate nav source.

Course Guidance: Nav 1 & Heading Indicator.

Partial Panel Approaches

GPS: Moving Map page (Nav 4).

Nav Source Selector Switch: Appropriate nav source.

Course Guidance: Nav 1 & TK information from GPS.



Cessna 172 Partial Panel Configuration

Garmin G1000

Enroute

PFD: Active with appropriate nav source (needles) active.

MFD: Map page with Traffic Information active. Range selected to view two future fixes.



G1000 Standard Configuration

Full Panel Approaches

PFD: Active with appropriate nav source (needles) active.

MFD: Map page with Traffic Information active. Range selected to view one or two future fixes.

Partial Panel Approaches

PFD: Dimmed.

MFD: Reversionary Mode.

Map Overlay: On with Traffic Information active.



G1000 Partial Panel Configuration

Enroute

GPS: Moving Map page (Nav 2), orientation set to TRACK UP.

VLOC Button: Selected to appropriate nav source.

Course Guidance: Nav 1 OBS or HSI, CDI Scaling - Auto.

Map Settings

MENU > Restore Defaults? > **ENT**

MENU > Setup Map? > **ENT**

ORIENTATION **PUSH** Track up **ENT**

Push **PUSH** To Remove Cursor

CDI Scaling

AUX Chapter **PUSH** Page 3

CDI / Alarms > **ENT**

Selected CDI **PUSH** AUTO

ILS CDI **PUSH** AUTO

(This verifies that CDI scaling uses standard GPS ranges for all modes of flight.)

Full Panel Approaches:

GPS: Moving Map page (Nav 2), orientation set to TRACK UP.

VLOC Button: Selected to appropriate nav source.

Course Guidance: Nav 1 OBS or HSI.

Partial Panel Approaches:

GPS: CDI page (Nav 1).

VLOC Button: Selected to appropriate nav source.

Course Guidance:

C172 – Nav 1 OBS and TRK information

PA44 – VOR, LOC, ILS: Nav 2 OBS and TRK information

RNAV/GPS: GPS CDI and TRK information

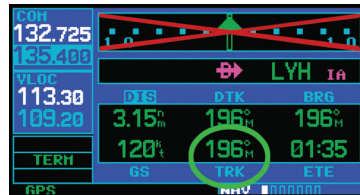

Cessna 172 Partial Panel Configuration

SECTION 3

Performance / Weight & Balance

V-Speeds (KIAS) & Limitations for R & S Models

Speeds listed below are in Knots Indicated Airspeed (KIAS).

	<i>R</i>	<i>S (& R w/ 72-01 Mod.)</i>	<i>Description</i>	<i>Airspeed Indicator Marking</i>
<i>Max Horsepower</i>	160hp	180hp		
<i>Max GTW (Normal)</i>	2,450lbs	2,550lbs		
<i>Max GTW (Utility)</i>	2,100lbs	2,200lbs		
<i>Max Ramp</i>	2,457lbs	2,558lbs		
<i>V_{SO}</i>	33	40	Stall speed in landing configuration	Bottom of White Arc
<i>V_S</i>	44	48	Stall speed in clean configuration	Bottom of Green Arc
<i>V_X</i>	60	62	Best angle of climb	
<i>V_Y</i>	79	74	Best rate of climb	
<i>V_A</i>	82 @ 1,600lbs 92 @ 2,000lbs 99 @ 2,450lbs	90 @ 1,900lbs 105 @ 2,550lbs	Maneuvering speed	
<i>V_R</i>		55	Rotation speed	
<i>V_{FE 10°}</i>		110	Maximum flap extension speed with 10° of flaps	
<i>V_{FE 20-30°}</i>		85	Maximum flap extension speed with 20-30° of flaps	Top of White Arc
<i>V_{NO}</i>		129	Maximum structural cruising speed	Top of Green Arc
<i>V_{NE}</i>		163	Never exceed speed	Red Line
<i>V_G</i>	65	68	Best glide speed	

Maximum demonstrated crosswind 15 knots



NOTE: Due to the diversity of the early models, it is not possible to have a condensed section of systems and v-speeds. Maximum GTW's range from 2,300 to 2,550, Max GTW's in the Utility category range from 2000-2100, and maximum horsepower ranges from 150 to 180 depending on model and modification. Pay close attention to the airspeed indicator as some are calibrated in both KIAS and MPH. Which indication is on the outer scale of the airspeed indicator varies by airplane.

Sample Weight & Balance Problem

Complete the following sample weight and balance problem for an S model.

Conditions

- Basic Empty Weight **1,740.9 lbs.**
(Remember to use actual aircraft BEW for flight check.)
- Front Pilots **350 lbs.**
- Rear Passengers..... **50 lbs.**
- Baggage **2 Bags @ 75 lbs.**
(May need to relocate some baggage to rear passenger seats.)
- Max Ramp Weight **2,558 lbs.**
- Max Takeoff/Landing Weight **2,550 lbs.**
- Max Baggage Weight **120 lbs.**
- Max Usable Fuel **53 gal.**
- Fuel Burn..... **10 gal.**

	Weight	×	Arm	=	Moment
Basic Empty Weight			41.57		
Front Pilots +			37.00	+	
Rear Passengers +			73.00	+	
Baggage 120 lbs. Max +			142.00	+	
Zero Fuel Weight =				CG =	
				CG = Moment / Weight	
Usable Fuel +			48.00	+	
Ramp Weight =					
Taxi Fuel (2.65 Gal.) -	8		48.00	-	384
Takeoff Weight =				CG =	
				CG = Moment / Weight	
Fuel Burn -			48.00	-	
Landing Weight =				CG	
				CG = Moment / Weight	

Calculate the Following

1. Zero Fuel Weight
2. Zero Fuel CG
3. Takeoff Weight
4. Takeoff CG
5. From comparing the Takeoff CG and Zero Fuel CG, which direction does the CG move as fuel is burned off?

Plot Zero Fuel CG and Takeoff CG on the CG Envelope Graph Below.

Answers: (1) 2,290.9 lbs. (2) 47.23 (3) 2,550 lbs. (4) 47.30 (5) Forward

Formulas

- $\text{Weight} \times \text{Arm} = \text{Moment}$
- $\text{Total Moment} \div \text{Total Weight} = \text{CG}$
- $\text{Max Ramp Weight} - \text{Zero Fuel Weight} = \text{Usable Fuel Weight}$
- $\text{Fuel Weight} \div 6 = \text{Fuel Gallons}$
- 100 LL (Blue) Fuel Weighs 6 lbs./gal.; Oil Weighs 7.5 lbs./gal.
- 3 Gallons of unusable fuel and oil at full capacity are Included in Basic Empty Weight

CG Envelope Graph

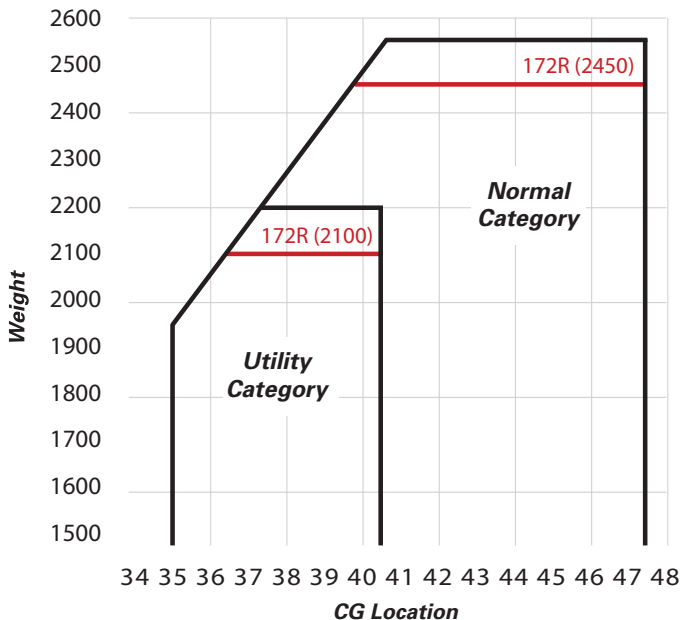

Departure Procedures

Normal Takeoff (Flaps 0°)

Do not delay on runway.

1. Line up on centerline positioning controls for wind
2. Hold brakes
3. Increase throttle to 2000 RPM
4. Check engine gauges
5. Release brakes
6. Increase throttle to full power
7. "Airspeed Alive"
8. Start slow rotation at 55 KIAS
(Main gear should lift off at approx. 60 KIAS. 55 KIAS is V_R , not V_{LOF})
9. Accelerate to 79 KIAS (V_Y)
(V_Y may vary depending on model. Refer to POH/AFM)
10. "After Takeoff Checklist" out of 1,000' AGL

Normal Takeoff Profile

Lined Up on Runway Centerline

- Hold Brakes
- Check Gauges at 2000 RPM
- Release Brakes
- Full Throttle

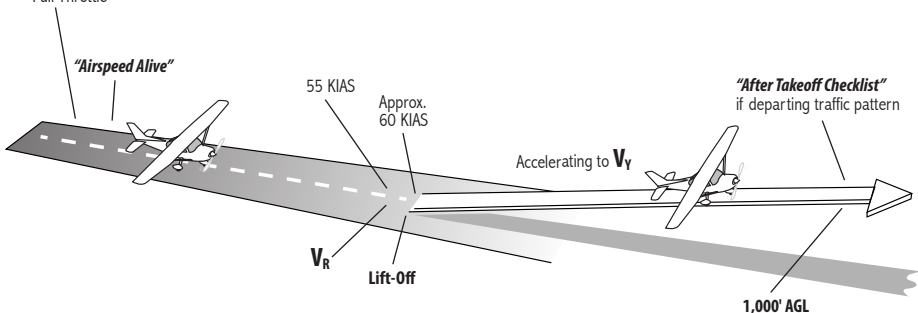

Short-Field Takeoff

1. Flaps 10°
2. Use all available runway
3. Hold brakes
4. Full throttle
5. Check engine gauges
6. At full power – release brakes
7. Rotate to climb at 57 KIAS over 50' obstacle
8. When clear of obstacle, accelerate V_Y
9. Flaps 0°
10. "After Takeoff Checklist" out of 1,000' AGL

Short-Field Takeoff Profile

Lined Up on Runway Centerline

- Flaps 10°
- Use All Available Runway
- Hold Brakes
- Full Throttle
- Check Engine Gauges
- At Full Power – Release Brakes

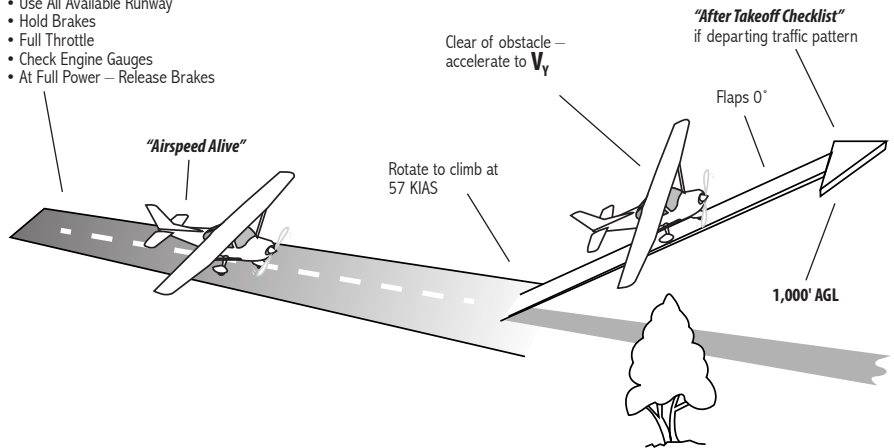

Soft-Field Takeoff

1. Flaps 10°
2. Roll onto runway with full aft yoke – minimum braking – do not stop
3. Smoothly apply full power – check engine gauges
4. As nose lifts off, ease back pressure
(Nose wheel must remain off ground)
5. Lift off at lowest possible airspeed – remain in ground effect
6. In ground effect – accelerate to 60 KIAS (V_X) – begin climb
7. Accelerate to 79 KIAS (V_Y)
8. At safe altitude, retract flaps
9. "After Takeoff Checklist" out of 1,000' AGL

Soft-Field Takeoff Profile

Roll Onto Runway with Full Aft Yoke

- Flaps 10°
- Minimum Braking - Do Not Stop
- Smoothly Apply Full Power – Check Engine Gauges

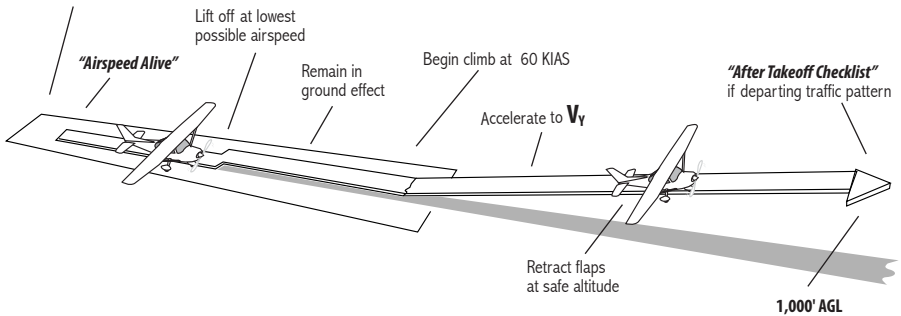

Engine Failure or Abnormality During Takeoff Roll

THROTTLES..... CLOSE
STOP STRAIGHT AHEAD & AVOID OBSTACLES

Insufficient Runway for Complete Stop

MIXTURE.....CUTOFF
FUEL SHUTOFF VALVE..... OFF
BATTERY MASTER OFF
IGNITION SWITCH..... OFF
AVOID OBSTACLES

Engine Failure Immediately After Takeoff

MAINTAIN AIRCRAFT CONTROL
LAND ON REMAINING RUNWAY OR
WITHIN 30° OF CENTERLINE. AVOID OBSTACLES.
DO NOT ATTEMPT 180° TURN.
AIRSPEED LOWER NOSE & PITCH FOR BEST GLIDE
FLAPS AS REQ
POWER AS AVAILABLE
TIME PERMITTING..... DECLARE AN EMERGENCY
FUEL SHUTOFF VALVE..... PULL OUT / OFF
IGNITION SWITCH OFF
FLAPS (40° Recommended) AS REQ
MASTER SWITCH OFF
DOORS..... UNLATCH

Engine Failure During Flight

AIRSPEED..... BEST GLIDE
NOTE WIND DIRECTION & SPEED
PICK & FLY TOWARDS LANDING SITE
FLAPS UP
MIXTURE RICH
FUEL SELECTOR VALVE BOTH
FUEL SHUTOFF VALVE..... PUSH IN / ON
AUX FUEL PUMP SWITCH..... ON
MAGNETOS CHECK ALL

If Prop Not Windmilling

IGNITION SWITCH..... START
MAGNETOS CHECK ALL

Arrival Procedures

Cessna 172 Landing Criteria

- Plan and brief each landing carefully.
- Enter the traffic pattern at TPA trimmed for 90 KIAS in level flight. (Landing profiles depend on this.)
- Maintain a constant angle glidepath.
- Whenever possible, fly the traffic pattern at a distance from the airport that allows for a power off landing on a safe landing surface in the event of an engine failure.
- Maintain final approach speed until roundout (flare) at approx. 10' to 20' above the runway.
- Reduce throttle to touch down with the engine idling and the airplane at minimum controllable airspeed within the first 1,000' of the runway.
- Touch down on the main gear, with the wheels straddling the centerline.
- Manage the airplane's energy so touchdown occurs at the designated touchdown point.
- Maintain a pitch attitude after touchdown that prevents the nosewheel from slamming down by increasing aft elevator as the airplane slows.
- Maintain centerline until taxi speed is reached and increase crosswind control inputs as airplane slows.
- Adjust crosswind control inputs as necessary during taxi after leaving the runway.

Good Planning = Good Landing

A good landing is a result of good planning. When planning an approach and landing, decide on the type of approach and landing (visual or instrument, short-field, soft-field, etc.). Decide on the flap setting, the final approach speed, the aiming point, and where the airplane will touch down on the runway surface.

Approach Briefing – Verbalize the Plan

During the Approach Checklist, conduct an approach briefing. This organizes the plan and ensures effective communication between pilots. The briefing should be specific to each approach and landing, but presented in a standard format that makes sense to other pilots and instructors.

Planning considerations:

- Flap Setting
- Type of Approach & Landing (visual, instrument, short-field, soft-field)
- Landing Runway
- Field Elevation
- Traffic Pattern Altitude
- Winds (left or right crosswind? tailwind on downwind or base?)
- Final Approach Speed
- Aiming Point
- Touchdown Point

Example VFR Briefing

Review the flap setting, aiming point, and touchdown point when established on downwind.

"This will be a normal flaps 20° landing. Aiming at the 3rd stripe before the 1,000' markings, touching down on the 1,000' markings.

This solidifies the plan between the student and instructor while visually indenting the aiming and touchdown points.



TIP: When approaching any airport for landing, have the airport diagram for available prior to landing and familiarize yourself with your taxi route based on your destination on the field and the landing runway.

Stabilized Approach

Definition: A stabilized approach is one in which the pilot establishes and maintains a constant angle glidepath towards a predetermined point on the landing runway. It is based on the pilot's judgment of certain visual cues, and depends on a constant final descent airspeed and configuration (FAA-H-8083-3A, p.8-7).

A stabilized approach is required during visual and instrument approaches in all ATP airplanes. The airplane must be stabilized by:

- 1,000' AGL for an ILS Approach
- Descending from MDA for a Non-Precision Approach
- 500' AGL for a Visual Approach

General Conditions for a Stabilized Approach

- Constant angle glidepath: Proper descent angle and rate of descent must be established and maintained. All available landing aids (ILS, VASI, PAPI, etc.) must be used. Non-precision approaches may require a slightly steeper angle until reaching MDA.
- Aircraft in final landing configuration (gear down and final flaps set).
- Airspeed must be stable and within range of target speed plus 10 KIAS.
- The aircraft will touch down in the first 1,000' of the landing runway. If this is not assured, a go-around must be executed.

Aiming Point

The Airplane Flying Handbook defines aiming point as "the point on the ground at which, if the airplane maintains a constant glidepath, and was not flared for landing, it would contact the ground."

AIM 2-3-3 – The "Runway Aiming Point Markings" consist of a broad white stripe located on each side of the runway centerline, approximately 1,000' from the landing threshold.

ATP requires all landings to occur within the first 1,000' of the landing runway. When flying a visual approach and landing in a C172, the (visual) aiming point chosen by the pilot is often an earlier point on the runway than the AIM defined "aiming point markings" to account for the flare. This technique ensures that the airplane touches down no farther than 1,000' down the runway.

Managing Energy

Managing energy means the pilot controls the airplane's glidepath, speed, and power setting so that altitude and airspeed are depleted simultaneously on the intended touchdown point.

Pitch & Power

Pitch

Maintain a constant angle glidepath to the aiming point by making pitch adjustments to keep the point stationary in the windshield. If the aiming point moves lower in the windshield, lower the pitch until the aiming point is back in the correct, stationary position. If the aiming point moves toward the top of the windshield, increase the pitch until the aiming point is back in the correct, stationary position.



TIP: During a visual approach and landing, if the airplane is trimmed for the correct approach speed with the correct power set, much of the pilot's attention can be on maintaining a constant angle glidepath to the aiming point. A majority of the pilot's scan should be outside the airplane, devoted to the aiming point and looking for traffic, with periodic instrument checks.

Power

During a stabilized approach and landing, use power to control deviations from the desired approach speed while maintaining a constant angle glidepath to the aiming point. If the airspeed is fast, reduce power while maintaining the constant angle glidepath. If the airspeed is slow, add power while maintaining the constant angle glidepath.

Since a constant angle glidepath is a requirement for a stabilized approach, airspeed deviations should be corrected by adjusting power. Changing pitch to correct airspeed deviations during a stabilized approach will cause an excursion from the constant angle glidepath, resulting in an unstable approach.



TIP: For training purposes landing is considered assured when the aircraft is lined up and will make the paved runway surface in the current configuration without power.

Go Around Philosophy

The decision to execute a go-around is both prudent and encouraged anytime the outcome of an approach or landing becomes uncertain. ATP considers the use of a go-around under such conditions as an indication of good judgement and cockpit discipline on the part of the pilot.



Instructors should vigilantly monitor student approaches and landing, and should command go-arounds if any of the stabilized approach conditions are not met. Instructors should make every effort to avoid allowing a student to take an unstabilized approach close to the ground, requiring the instructor to take the controls and initiate a go-around.

Gust Factor

Slightly higher approach speeds should be used under turbulent or gusty wind conditions. Add $\frac{1}{2}$ the gust factor to the normal approach speed. For example, if the wind is reported 8 gusting to 18 knots, the gust factor is 10 knots. Add $\frac{1}{2}$ the gust factor, 5 knots in this example, to the normal approach speed.

Flap Setting

The C172 Operations Manual p. 4-32 states: "Normal landing approaches can be made with power on or power off with any flap setting desired. Surface winds and air turbulence are usually the primary factors in determining the most comfortable approach speeds."

Students must be able to determine the best flap configuration and approach speed given the landing conditions.



At ATP, students are trained to land using the Standardized Flaps 20° Landing profile, located on page 24. When conditions are necessary for soft-field or short-field landing practice, those profiles should be used.

Seat Position

Correctly positioning the seat exactly the same for each flight improves landing performance and safety.

The fore-aft adjustment is correct when the heels are on the floor with the balls of the feet on the rudder pedals, not on the brakes. The feet should be at a 45° angle from the floor to the pedals and the pilot should be able to apply full rudder inputs without shifting their body weight. When braking is required, lift the foot from the floor rather than keeping the leg suspended in the air or resting the feet on the upper portion of the pedals.

The seat height should be adjusted so the pilot can see the curvature of the cowling for the best sight picture during landing.



TIP: Proper foot position helps prevent inadvertent brake application during landings and ground operations.

Traffic Pattern Operations

Pattern Briefings should include:

- Flap Setting
- Type of Approach & Landing (Short-Field, Soft-Field, etc.)
- Final Approach Speed
- Aiming Point
- Touchdown Point

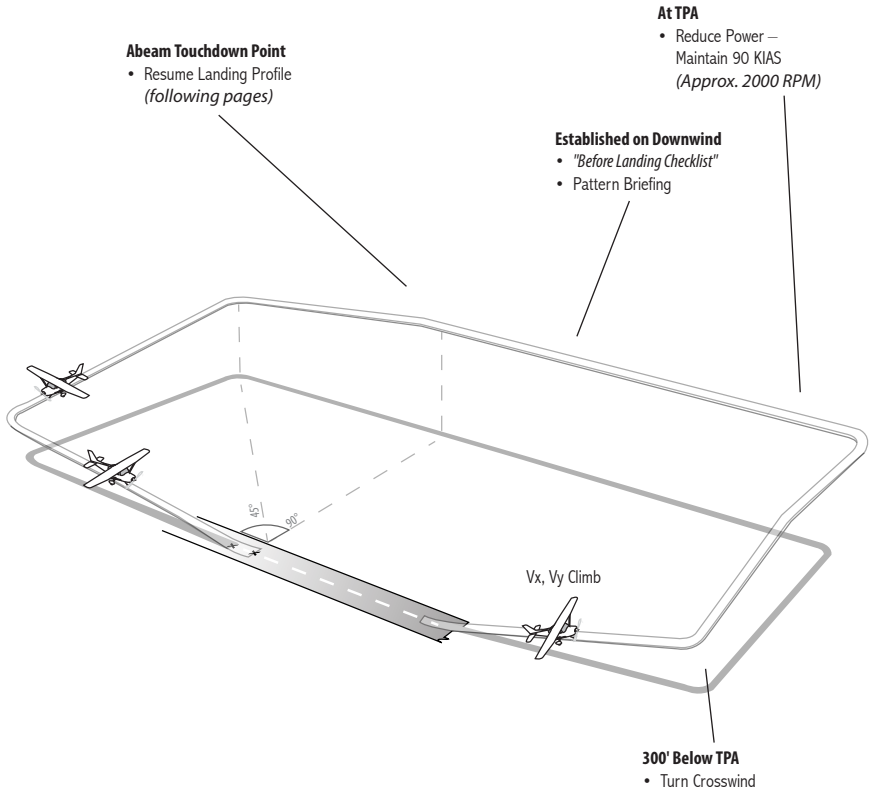

Standardized Flaps 20° Approach & Landing

1. Complete the “*Approach Checklist*” before entering the airport area; devote full attention to aircraft control and traffic avoidance
2. Slow to 90 KIAS prior to entering downwind or traffic pattern
3. Enter the traffic pattern at published TPA (typically 1,000' AGL)
4. Complete the “*Before Landing Checklist*” when established on downwind
5. When abeam touchdown point, on extended base, or on extended final (when ready to descend out of pattern altitude): Reduce power to approx. 1500 RPM and select flaps 10°
6. Descend out of TPA at 70-80 KIAS
7. On base leg, select flaps 20° and slow to 70 KIAS
8. Maintain 70 KIAS until short final when landing is assured, then slow to 65 KIAS until 10' to 20' above the runway



TIP: Getting ATIS, briefing the approach, and the Approach Checklist should be completed no later than 15 miles from the airport. Accomplishing these tasks as early as possible creates more time to focus on aircraft control and collision avoidance in the busy airport environment. During training flights when maneuvering near an airport, get ATIS, brief, and complete the Approach Checklist as soon as the decision is made to return to the airport. Don't wait!

Before Landing Checklist

FUEL SELECTOR.....ON
MIXTUREFWD
CARB HEAT (carbureted models)ON

Standardized 20° Flap Setting for C172 Landings Profile

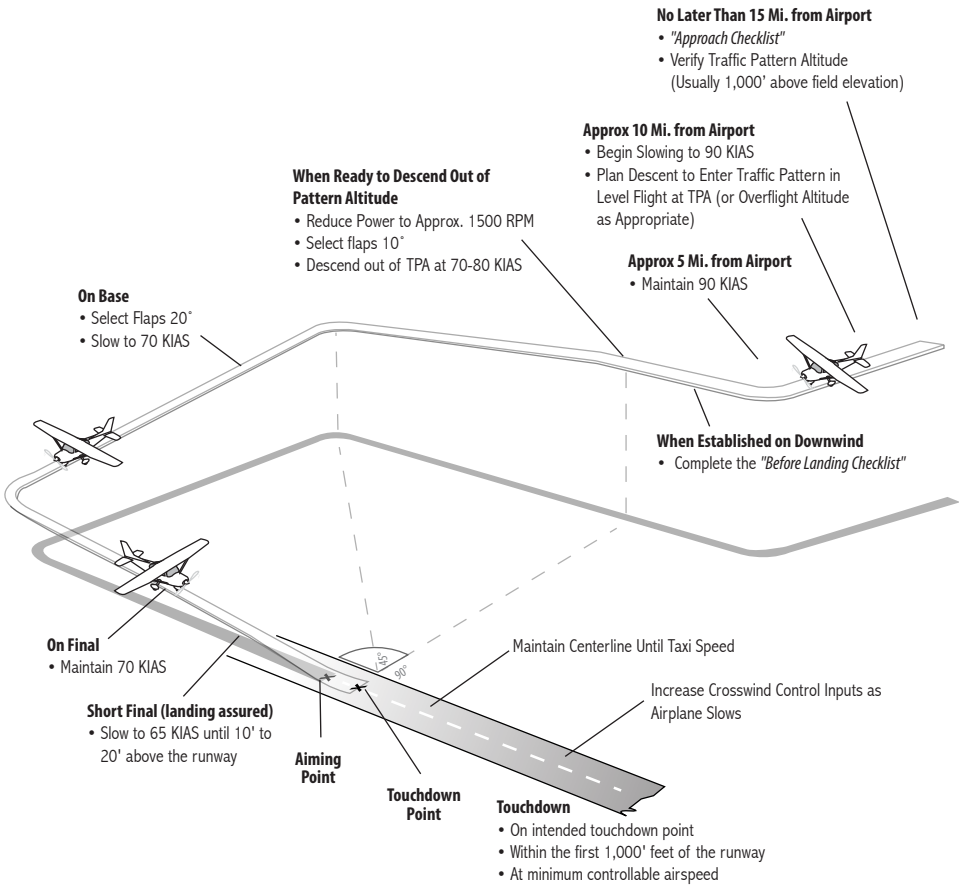

TIP: The power settings in this supplement are approximate and can change depending on prevailing conditions. A common mistake is to spend too much time trying to set exact power settings. This diverts the pilot's attention from more important things. During landings, limit attention to the gauges to a few seconds at a time so ample attention remains on flying the proper course and glidepath.

Flaps 10° Approach & Landing (ILS Approach)

A flaps 10° approach and landing will be accomplished the same as a standardized flaps 20° approach and landing with a few differences:

- Slow to 70 KIAS on base. Do not select flaps 20°.
- Maintain 70 KIAS until final when landing is assured, then slow to 65 KIAS until 10' to 20' above the runway.



TIP: Under normal circumstances, avoid configuration changes below 400' AGL whenever possible.



VIDEO: For more information about proper landing technique, watch "Land Like a Pro" available on the ATP Flight School iPad app.

No-Flap Approach & Landing

Steps 1-4 are identical to a normal approach and landing procedure.

5. When abeam touchdown point, on extended base, or on extended final (when ready to descend out of pattern altitude): Reduce power to approx. 1300 RPM
6. Slow to 70 KIAS
7. Descend out of TPA at 70 KIAS
8. Maintain 70 KIAS until landing is assured, then slow to 65 KIAS until 10' to 20' above the runway

No Flap Approach & Landing Profile

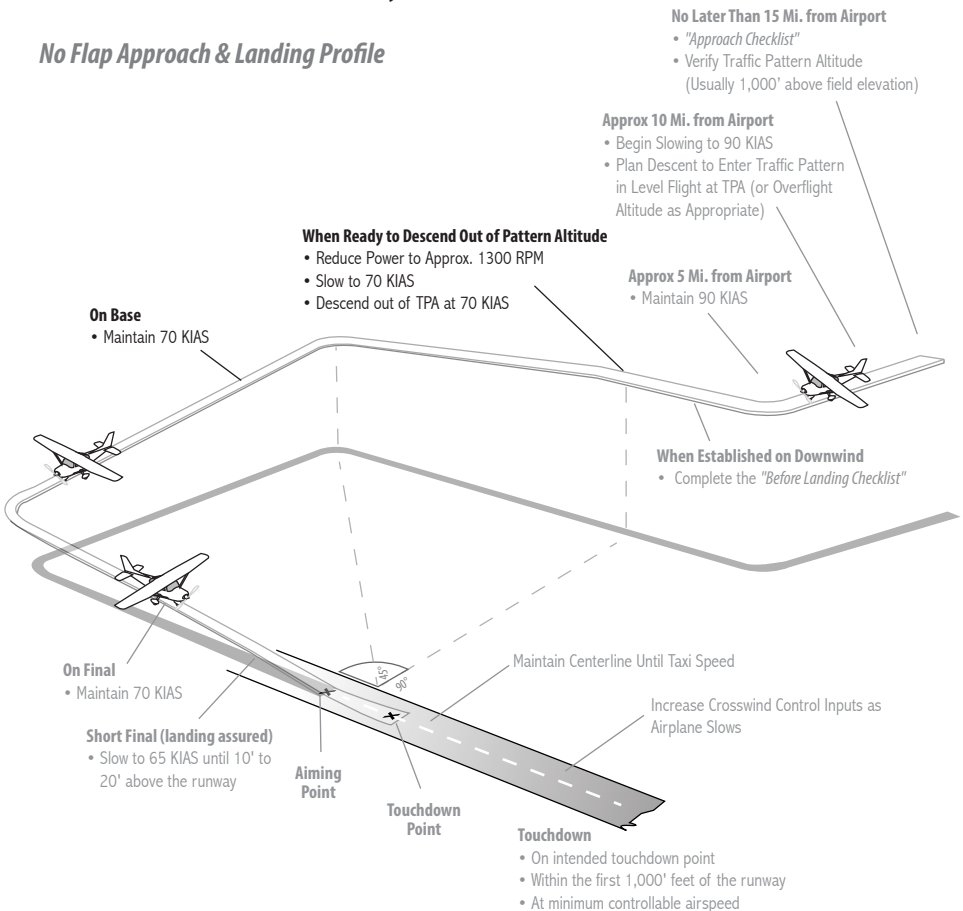

TIP: A no-flap approach has a different sight picture than a normal, flaps 20° approach. Don't add airspeed beyond profile speeds to compensate for the different sight picture. This will lead to excessive float in ground effect.

Short-Field Approach & Landing

Steps 1-7 are identical to a normal approach and landing procedure.

8. Select flaps FULL and slow to 62 KIAS on final when landing is assured
9. Close throttle slowly during flare – touch down on intended touchdown point with little or no floating
10. Prevent the nosewheel from slamming onto the runway
11. Retract the flaps after touchdown
12. Simulate and announce “Max Braking” for training and checkride purposes

Short-Field Approach & Landing Profile

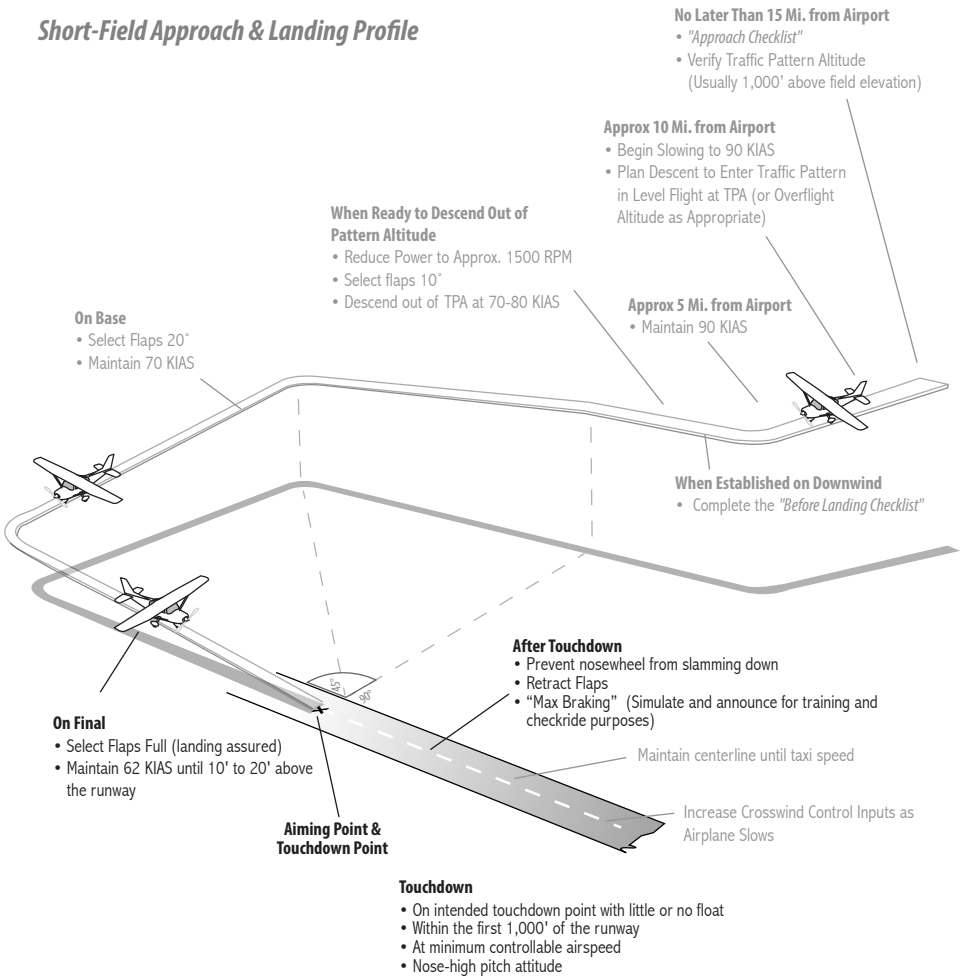

Soft-Field Approach & Landing

Steps 1-7 are identical to a normal approach and landing procedure.

8. On short final when landing is assured, select flaps 30° and slow to 65 KIAS
9. Fly the airplane onto the ground, slowly transferring the weight from the wings to the main landing gear
10. Touch down on intended touchdown point at minimum speed with a nose-high pitch attitude
11. Keep the nosewheel off the ground as airplane slows by increasing elevator pressure
12. Prevent nosewheel from rapidly falling by maintaining aft elevator pressure

Soft-Field Approach & Landing Profile

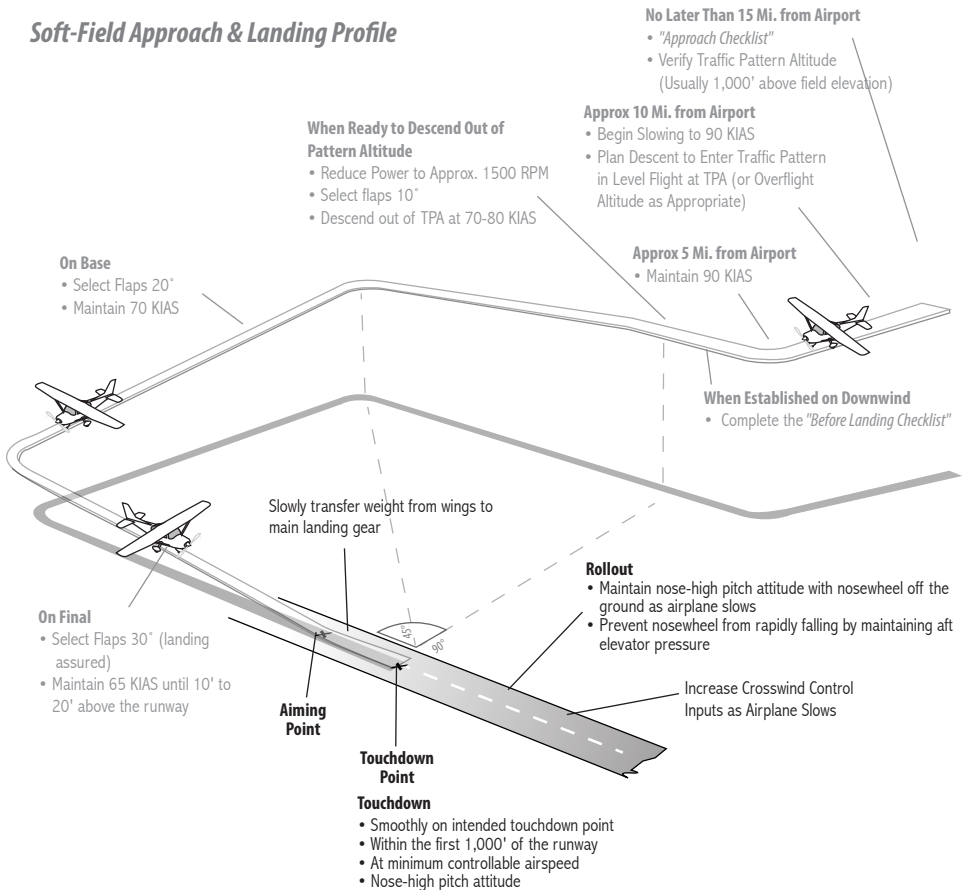

Crosswind Approach & Landing

Carefully planned adjustments must be made to the normal approach and landing procedure to safely complete a crosswind approach and landing.

Planning

Before entering the traffic pattern, brief how your approach and landing will be different by acknowledging the wind direction, crosswind component, planned flap setting, and how your traffic pattern ground track will differ as a result of the winds.

Flap Setting

The Cessna POH/AFM recommends using the “minimum flap setting required for the field length. If flap settings greater than 20° are used in sideslips with full rudder deflection, some elevator oscillation may be felt at normal approach speeds.” ATP standardized landing technique for the C172 and the C172 POH/AFM recommend the wing-low method for best control. It is highly recommended that flap settings be limited to 20° during crosswind operations.

Ground Track

Plan a crab angle on downwind to maintain a uniform distance from the runway. Begin the base turn so the airplane is established on base at the appropriate distance from the runway. Do not allow the winds to blow the airplane off the intended ground track. Turning final, adjust for the winds to not over or undershoot the runway centerline.

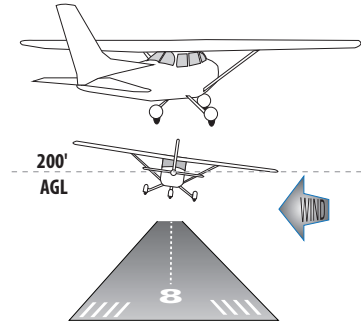

Control Technique

Establish a crab angle to maintain the proper ground track on final, then transition to the wing-low sideslip technique by no later than 200' AGL and below. Maintain the wing-low technique until touchdown and throughout the landing roll. After landing, increase aileron input into the wind as the airplane slows to prevent the upwind wing from rising, reduce side-loading tendencies on the landing gear, and minimize the risk of roll-over accidents due to the upwind wing lifting.

Judgment

The demonstrated crosswind component in the C172 is 15 knots. Regardless of reported winds, if the required bank to maintain drift control is such that full opposite rudder is required to prevent a turn toward the bank, the wind is too strong to safely land the airplane. Select another runway or airport and go-around any time the outcome of an approach or landing becomes uncertain.

TIP: During windy conditions, adjust turns in the traffic pattern as necessary to maintain the correct ground track and distance from the runway. For example, a strong tailwind during the downwind leg will blow the airplane too far from the runway if the pilot waits until the 45° point to turn base. Instead, plan the base turn early to remain the correct distance from the runway.

Crosswind Approach & Landing Profile

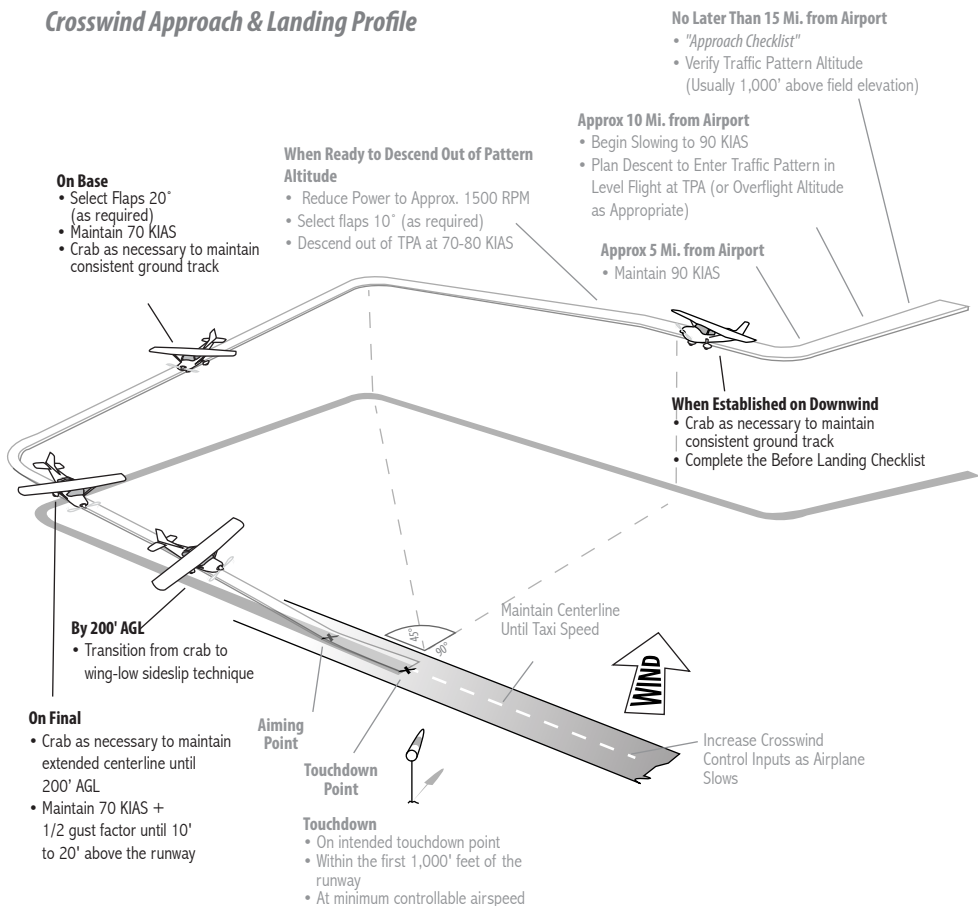

TIP: Develop the habit of applying full, proper crosswind control inputs as the airplane slows during every landing rollout and all taxi operations, regardless of how light the winds. Resist the tendency to release the control inputs to neutral after touchdown.

Go-Around

A go-around procedure must be initiated any time the conditions for a safe approach and landing are not met. Some examples of unsatisfactory approach and landing conditions are:

- Unstable approach path or airspeed.
- Improper runway alignment.
- Unexpected hazards on the runway or on final.
- Anything that jeopardizes a safe approach and landing.

Any time unsafe or unsatisfactory conditions are encountered, a go-around must be immediately executed and another approach and landing should be made under more favorable conditions.



TIP: Flaps should always be retracted in 10° increments.

- Flaps 20° immediately (if flaps > 20°).
- Flaps 10° accelerating through 55 KIAS.
- Flaps 0° at 65 KIAS and clear of obstacles.

Missed Approach

A missed approach is a maneuver conducted by a pilot when an instrument approach cannot be completed to a landing. The pilot's initial actions when initiating a missed approach are the same as a go-around procedure.

Go-Around / Missed Approach Procedure

1. Increase throttle to full power
2. Retract flaps to 20° (if > 20°) while simultaneously;
3. Increase pitch to establish climb
4. Retract flaps to 10° when airspeed is greater than 55 KIAS
5. Establish V_X or V_Y as appropriate
6. Retract flaps to 0° at 65 KIAS and clear of obstacles
(if no obstacles)
7. "After Takeoff Checklist" out of 1,000' AGL if departing the traffic pattern

If the go-around or missed approach is due to conflicting traffic, maneuver as necessary during the climb to clear and avoid conflicting traffic (usually to the side, flying parallel to the runway).

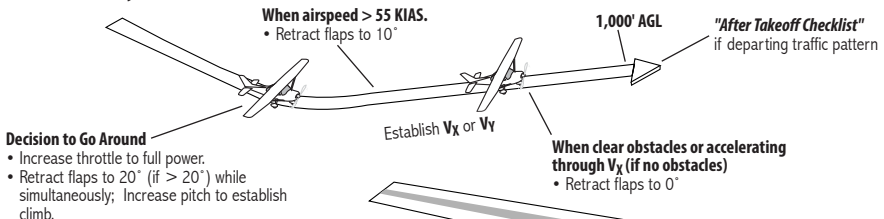

Rejected or Balked Landing

A rejected or balked landing occurs when the airplane is very low to the ground and usually occurs after the roundout (flare) has begun. Airspeed may be very low – well below V_X or V_Y in some cases – and the pilot must be very careful to establish and maintain a safe airspeed during the transition to a climb. At slow airspeeds, retracting the flaps too early or abruptly can result in a significant loss of lift. The pilot must also factor in ground effect when initiating a rejected or balked landing close to the ground.

Rejected or Balked Landing Procedure

1. Increase throttle to full power
2. Retract flaps to 20° (if $> 20^\circ$) while simultaneously;
3. Accelerate to 55 KIAS (if slower) then;
4. Increase pitch to establish climb
5. Retract flaps to 10° accelerating through 55 KIAS
6. Accelerate to V_X or V_Y as appropriate
7. Retract flaps to 0° when clear obstacles or accelerating through V_X (if no obstacles)
8. "After Takeoff Checklist" out of 1,000' AGL if departing the traffic pattern

If the rejected landing is due to conflicting traffic, maneuver as necessary during the climb to clear and avoid conflicting traffic (usually to the side, flying parallel to the runway).

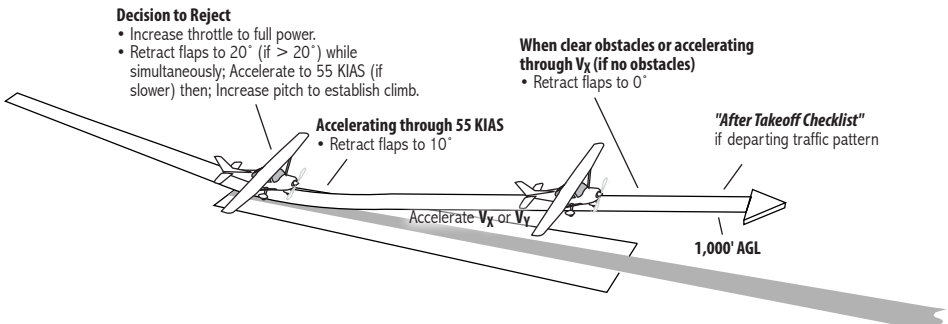

The terms go-around, missed approach, rejected landing, and balked landing are often used interchangeably, but there are differences.

Precision Approach (ILS Approach)

1. Complete the "Approach Checklist" and identify the localizer as early as possible
2. Slow to 90 KIAS on vectors or when final approach course inbound
3. Announce "Localizer Alive" when localizer begins moving toward center
4. Announce "Glideslope Alive" when glideslope begins moving toward center
5. Verify no flags at glideslope intercept altitude and marker
6. 1/2 dot below glideslope intercept: "Before Landing Checklist"
7. Reduce power to approx. 1500 RPM, and select flaps 10°.
8. Descend on glideslope at 80 KIAS.
9. Announce at 1,000' above DA: "1,000 to go"
10. Announce at 100' above DA: "100 to go"
11. "Minimums"
12. Runway in sight: descend and slow to 70 KIAS
13. On short final, slow to 65 KIAS until 10' to 20' above the runway

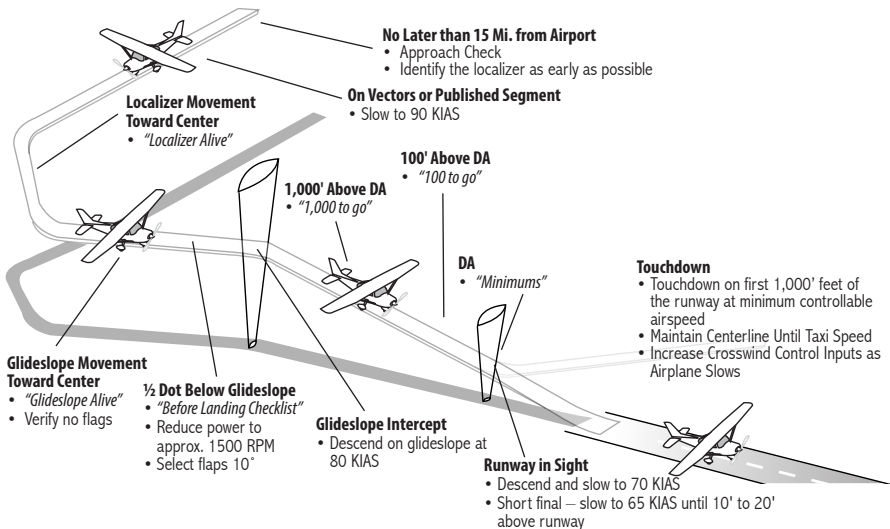

TIP: The airplane is considered established inbound when the localizer is alive.

Non-Precision Approach (GPS, VOR, LOC Approach)

1. Load the approach into the GPS, and select appropriate nav source, and frequency if required.

Within 30 NM of the airport, if flying a GPS approach, the GPS will display "Apch Arm" or "TERM."

2. Set the desired course on the Nav 1 OBS.
3. Complete the "Approach Checklist."
4. Slow to 100 KIAS no later than 15 NM from the IAF or if on vectors.
5. Slow to 90 KIAS intercepting final approach course inbound.
6. 2 NM prior to FAF, complete "Before Landing Checklist" - Flaps 10° - Slow to 80 KIAS.

At 2 NM prior to the FAF on a GPS approach, verify green APCH ACTV or APCH flag on GPS. If no flag appears, DO NOT DESCEND at the FAF.

7. At FAF: Start time if required.
8. Descend at 400-500 FPM (unless steeper descent required) at 80 KIAS.
9. Announce at 100' above minimums: "100 to go."
10. Increase power 50' prior to reaching MDA to maintain 80 KIAS at level off.
11. "Minimums."
12. Maintain MDA (plus 50', minus 0').
13. Runway in sight: descend at predetermined VDP or maintain MDA to MAP.
14. Do not leave MDA until landing is assured.
15. When descending from MDA: Flaps 20° - 70 KIAS.
16. On short final, slow to 65 KIAS until 10' to 20' above the runway.

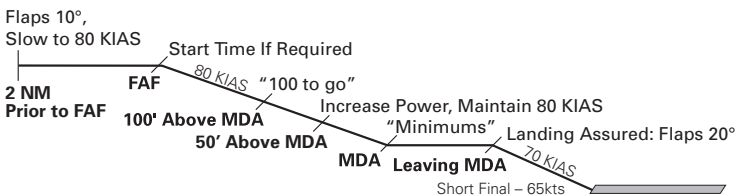

Circling Approach

When conducting a circling approach, fly the normal approach profile to the published circling minimums (precision or non-precision).

Maintain circling minimums at 80 KIAS until in a position from which a normal landing can be made.

When descending from MDA (circling minimums), select flaps 20° and slow to 70 KIAS. On short final, slow to 65 KIAS until 10' to 20' above the runway.

In-Flight Maneuvers



NOTE: Configuration and throttle settings used throughout the following procedures are based on an 160 HP R-Model 172 and will vary depending on the specific airplane and prevailing conditions.

Required maneuvers for the Commercial Pilot Single-Engine Add-On are performed the same as those for Private Pilot, with exception of steep turns, which is accomplished with at least 50° of bank.

Commercial Pilot Single Engine Add-On completion standards allow for lower tolerances than Private Pilot standards on maneuvers. Refer to the PTS.

Clean Configuration Flow

1. Fuel selector – both
2. Mixture – enrichen
3. Flaps 0°

Landing Configuration Flow

1. Fuel selector – both
2. Mixture – enrichen
3. Carburetor heat – on (carbureted models)
4. Flaps full

PVT

Steep Turns

Steep turns are to be accomplished above 3,000' AGL. Roll into one coordinated 360° turn, then follow with another coordinated 360° turn in the opposite direction. Roll into and out of turns at approximately the same rate.

1. Perform two 90° clearing turns
2. 90 KIAS (2000 RPM) maintain altitude
3. Cruise configuration flow
4. Perform a 360 turn with 45° of bank
5. Maintain altitude and airspeed (+ back pressure, + approx. 1-200 RPM)
6. Roll out ½ bank angle prior to entry heading
7. Clear traffic and perform a 360° turn with 45° of bank in the opposite direction
8. Roll out ½ bank angle prior to entry heading
9. "Cruise Checklist"

 PRACTICAL TEST	Airspeed	Altitude	Bank	Heading
	±10 KIAS	±100'	45° ±5°	±10°

PVT

Maneuvering During Slow Flight

Slow flight is to be accomplished at an entry altitude that will allow completion above 1,500' AGL. The airspeed selected is that at which any further increase in angle of attack, increase in load factor, or reduction in power, would result in an immediate stall.

1. Perform two 90° clearing turns
2. 1500 RPM (maintain altitude)
3. Landing configuration flow
4. Maintain altitude – slow to just above a stall
5. Power as required to maintain airspeed
6. Accomplish level flight, climbs, turns, and descents as required
ATP - max 30° bank
7. Recover – max power/maintain altitude/reduce flaps.
8. Above V_X , retract flaps to 0°
9. "Cruise Checklist."

 PRACTICAL TEST	Airspeed	Altitude	Bank	Heading
	+10/-0 KIAS	±100'	±10°	±10°

PVT

Power-Off Stall

Stalls are to be accomplished at an entry altitude that will allow completion no lower than 1,500' AGL. This maneuver is begun by first establishing a stabilized descent in either the approach or landing configuration.

1. Perform two 90° clearing turns
2. 1500 RPM (maintain altitude)
3. Landing configuration flow
4. Stabilized descent at 65 KIAS
5. Throttle idle (slowly)
6. Wings level or up to 20° bank as assigned
7. Maintain altitude to induce stall
8. Recover – simultaneously reduce AOA, max power, and level wings
9. Retract flaps to 20° (immediately)
10. Retract flaps to 10° when airspeed is greater than 55 KIAS
11. Increase pitch to arrest descent
12. Establish V_X or V_Y as appropriate
13. Retract flaps to 0° when accelerating through V_X
14. "Cruise Checklist."

 PRACTICAL TEST	Bank	Heading
	±10° <i>Not to exceed 20°</i>	±10°

PVT

Power-On Stall

Stalls are to be accomplished at an entry altitude that will allow completion no lower than 1,500' AGL.

1. Perform two 90° clearing turns
2. 1500 RPM (maintain altitude)
3. Clean configuration flow
4. At 60 KIAS, simultaneously increase pitch (slowly) and apply full power
5. Increase pitch attitude to induce stall
6. At stall/buffet (as required) recover – simultaneously reduce AOA, max power, and level wings
7. "Cruise Checklist"

 PRACTICAL TEST	Bank	Heading
	±10° <i>Not to exceed 20°</i>	±10°

PVT **Emergency Descent**

During a simulated emergency descent, the applicant must be able to recognize situations requiring an emergency descent, such as cockpit smoke and/or fire. Situational awareness, appropriate division of attention, and positive load factors should be maintained during the maneuver and descent.

1. Perform two 90° clearing turns
2. Clean configuration flow
3. Reduce throttle to idle
4. Initiate turning descent, while clearing for traffic
5. Maintain (training) 120 KIAS
6. Notify ATC/Traffic as appropriate

COM **Chandelles**

Chandelles are to be accomplished at an entry altitude that will allow completion no lower than 1,500' AGL, and consist of one maximum performance climbing turn beginning from straight-and-level flight, and ending at the completion of a precise 180° turn in a wings-level, nose-high attitude at the minimum controllable airspeed.

1. Perform two 90° clearing turns
2. 100 KIAS (2200 RPM) maintain altitude
3. Clean configuration flow
4. Choose a reference point off wing
5. Establish / maintain 30° bank
6. Full Throttle - Increase pitch to attain approx. 10-12° pitch up at 90° point
1st 90° of turn, Bank = constant 30°, Pitch = increasing to 10-12° pitch up
7. 90° point - maintain pitch - reduce bank angle to attain level flight at 180° point
2nd 90° of turn, Pitch = constant 10-12° pitch up, Bank = decreasing to level flight
8. 180° point - wings level - minimum controllable airspeed
9. Accelerate while maintaining level flight
10. "Cruise Checklist"

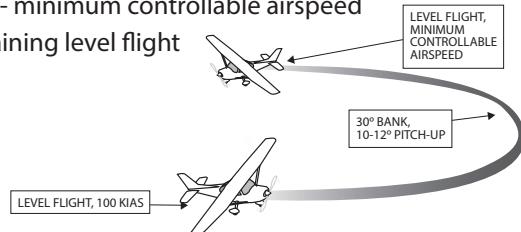

PRACTICAL TEST	Airspeed	Heading
	Just above stall	Rollout at 180° point ±10°

COM **Lazy Eights**

Lazy Eights are to be accomplished at an entry altitude that will allow the task to be completed no lower than 1,500' AGL. The applicant is required to maintain coordinated flight throughout the maneuver, with a constant change of pitch and roll rate.

1. Perform two 90° clearing turns
2. 100 KIAS (2200 RPM) maintain altitude
3. Clean configuration flow
4. Choose a reference point off of the wing
5. Simultaneously increase pitch and bank (slowly)
6. 45° point – 15° pitch up and 15° bank
7. Reduce pitch / increase bank
8. 90° point – level pitch - 30° bank - min. speed (5-10 knots above stall)
9. Continue reducing pitch and reduce bank
10. 135° point – 15° pitch down - 15° bank
11. 180° point – level flight – entry airspeed and altitude
12. Repeat in opposite direction
13. "Cruise Checklist"

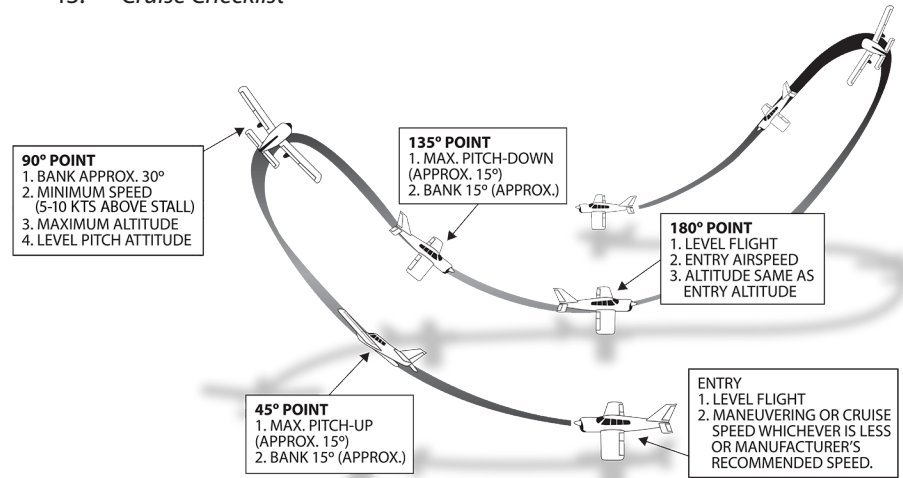

*Pitch and bank reference numbers approximate.

PRACTICAL TEST	At 180° points:	Airspeed	Altitude	Heading
		±10 KIAS	±100'	±10°

COM

Eights On Pylons

Eights on Pylons are to be accomplished at the appropriate pivotal altitude (groundspeed²/11.3), governed by the aircraft's groundspeed. The applicant is required to maintain coordinated flight while flying a figure eight pattern which holds the selected pylons using the appropriate pivotal altitude. At the steepest point, the angle of bank should be approximately 30-40°.

1. Enter pivotal altitude (approximately 900' AGL at 100 KIAS - 2200 RPM)
2. Perform two 90° clearing turns
3. Clean configuration flow
4. Select two pylons to allow for minimal time spent wings level between the two
5. Enter maneuver on a 45° midpoint downwind
6. Apply appropriate pitch corrections to compensate for changes in groundspeed and;
7. To maintain line of sight reference with the pylon (pitch forward if point moves toward nose and pitch back if point moves toward tail)
8. Begin rollout to allow the airplane to proceed diagonally between the pylons at a 45° angle
9. Begin second turn in the opposite direction of the first
10. Exit maneuver on entry heading
11. "Cruise Checklist"

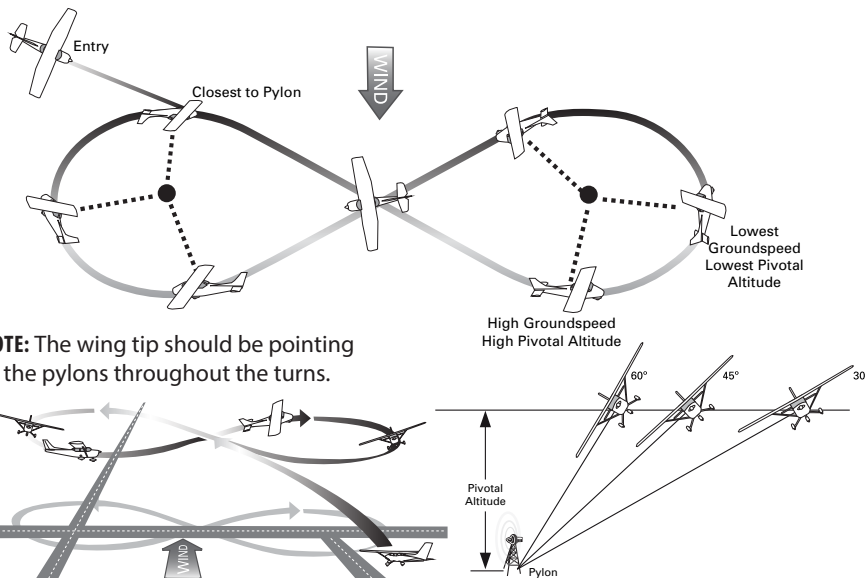

COM

Steep Spirals

1. Altitude – at least 3,000' AGL
2. Perform two 90° clearing turns
3. 80 KIAS (1700 RPM) maintain altitude
4. Clean configuration flow
5. Choose visual reference point
6. Reduce throttle to idle
7. Track at least three constant radius circles around reference point
8. Airspeed – constant
9. Bank angle – adjust for winds – not to exceed 60°
10. Clear engine once every 360° turn
11. Recover – roll out on specified heading (visual reference)
12. Adjust DG/HSI to compass
13. "Cruise Checklist"

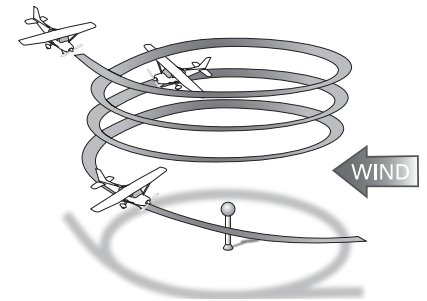

Airspeed
±10 KIAS

Heading
Rollout towards specified heading or point ±10°

COM

Accelerated Stall

Accelerated stalls are accomplished at an altitude that allows completion no lower than 3,000 feet AGL. A smooth transition should be made from cruise attitude to a bank angle of 45°, maintaining coordinated turning flight, while increasing elevator back pressure steadily to induce the stall.

1. Perform two 90° clearing turns
2. Slow to approximately 60 KIAS (during clearing turns)
3. Clean configuration flow
4. Establish a coordinated 45° bank turn
5. Slowly reduce power to idle
6. Maintain altitude to induce stall
7. Recover at the onset (buffeting) stall condition
8. Simultaneously reduce AOA, max power, and level wings
9. "Cruise Checklist"

CFI

Secondary Stall (Power-On)

Secondary Stalls are to be accomplished above 3,000 AGL. The purpose is to demonstrate the effect of attempting to hasten the completion of a stall recovery before the airplane has regained sufficient flying speed. Demonstrate and simultaneously explain secondary stalls from an instructional standpoint.

1. Perform two 90 clearing turns
2. 1500 RPM (maintain altitude)
3. Clean configuration flow
4. At 60 KIAS, simultaneously increase pitch (slowly) and apply full power
5. Increase pitch attitude to induce stall
6. At stall, recover – simultaneously reduce AOA, max power, and level wings
7. When stall horn silences, increase pitch to induce a secondary stall
8. At stall, recover – simultaneously reduce AOA, max power, and level wings
9. "Cruise Checklist"

CFI

Secondary Stall (Power-Off)

Secondary Stalls are to be accomplished above 3,000 AGL. The purpose is to demonstrate the effect of attempting to hasten the completion of a stall recovery before the airplane has regained sufficient flying speed. Demonstrate and simultaneously explain secondary stalls from an instructional standpoint.

1. Perform two 90 clearing turns
2. 1500 RPM (maintain altitude)
3. Landing configuration flow
4. Stabilized descent at 65 KIAS
5. Throttle idle (slowly)
6. Maintain altitude to induce stall
7. At stall, recover – simultaneously reduce AOA and level wings (do not add power)
8. When stall horn silences, increase pitch to induce a secondary stall
9. At stall, recover – simultaneously reduce AOA, max power, and level wings
10. Retract flaps to 20° (immediately)
11. Retract flaps to 10° when airspeed is greater than 55 KIAS
12. Increase pitch to arrest descent
13. Establish V_X or V_Y as appropriate.
14. Retract flaps to 0° when accelerating through V_Y
15. "Cruise Checklist"

CFI

Elevator Trim Stall

Elevator Trim Stalls are to be accomplished above 3,000 AGL. The purpose is to demonstrate what can happen when full power is applied for a go-around and positive control of the airplane is not maintained. Demonstrate and simultaneously explain elevator trim stalls from an instructional standpoint.

1. Perform two 90 clearing turns
2. 1500 RPM (maintain altitude)
3. Landing configuration flow
4. Trim for stabilized descent at 65 KIAS
5. Apply full power (slowly)
6. Allow the nose to rise and turn left
7. When stall is approaching (high AOA) recover – simultaneously reduce AOA, max power, and level wings
8. Adjust trim while accelerating to V_Y
9. Retract flaps to 0° at 65 KIAS
10. "Cruise Checklist"

CFI

Cross-Control Stall

Cross-Control Stalls are to be accomplished above 3,000 AGL. The purpose is to demonstrate the effect of improper control technique and to emphasize the importance of using coordinated control pressures whenever making turns. This demonstration shows what can happen during poorly executed base-to-final turn where too much rudder is applied in the direction of the turn. Demonstrate and simultaneously explain cross-control stalls from an instructional standpoint.

1. Perform two 90 clearing turns
2. 1500 RPM (maintain altitude)
3. Clean configuration flow
4. Stabilized descent at 65 KIAS
5. Establish a 30° banked turn
6. Smoothly apply excessive rudder pressure in the direction of the turn
7. As rudder pressure increases, opposite aileron will be necessary to maintain constant bank angle
8. Increase aft elevator pressure
9. At first indication of stall, recover – simultaneously reduce AOA, max power, and level wings
10. "Cruise Checklist"

Oral Review

Lost Comm Procedure (FAR 91.185)

If in VFR conditions, or if VFR conditions are encountered, squawk 7600, remain VFR and land as soon as practicable.

If in IFR conditions, squawk 7600 and Fly:

Route <i>(First that applies)</i>	Altitude <i>(Whichever is highest until descent is required for landing)</i>
Assigned	Minimum IFR Altitude
Vectored	Expected
Expected	Assigned
Filed	

FAR Review

1. To maintain instrument currency, a pilot must have made six approaches and demonstrated proper holding procedures as well as radial and bearing tracking in the last six months.
2. An alternate is not required if the weather at your destination is forecast to be at least a 2,000' ceiling and visibility of at least three miles. The forecast must be from one hour before to one hour after your estimated time of arrival.
3. If an alternate airport is needed, forecasted weather at ETA must be at least 600' ceiling and 2 miles visibility for a precision approach; an alternate airport that offers only a non-precision approach must be at least 800' ceiling and 2 miles visibility. An alternate cannot be based on a GPS approach.
4. Reserve fuel of 45 minutes is required for IFR flights; 30 minutes for VFR day flights; and 45 minutes for VFR night flights. This reserve is required in addition to the fuel required to fly to your destination and alternate.

5. VOR limits: 4 degrees for VOT, ground checkpoint and dual check. 6 degrees for an airborne check.
6. VOR equipment must be checked every 30 days.
7. Transponders must be checked every 24 calendar months.
8. Pitot static systems must be checked every 24 calendar months.
9. ELT equipment must be checked every 12 months, after half of the battery life, or after 1 hour of cumulative use.
10. An aircraft used for hire must have a 100 hour and an annual inspection.
11. In order to descend below the DH or MDA, all of the following conditions must exist:
 - A. The required flight visibility is met.
 - B. The aircraft is in a normal position to land.
 - C. (1) The runway environment is in sight – descend to land.
(2) Approach lights in sight – descend to 100' above touch down zone until runway environment is in sight.
(3) Descend and land if red terminating bars or red side row bars are in sight.
12. The minimum equipment list includes a list of equipment that may be inoperative for a particular phase of flight. If not required to have a MEL, comply with the minimum equipment prescribed by the FAR's.
13. Standard Traffic Pattern Altitude (TPA) is 1,000' AGL.

Answer The Following Sample Oral Questions Prior To Arriving For Training

1. (True/False) Engines on all ATP C172s are identical.
2. Identify the range of useable fuel (smallest to largest) available in the ATP C172 fleet.
3. Where (within the POH/AFM) can information on engine modifications be found?
4. Be able to identify the various engine sizes and specifications for the various model C172s.
5. What type of flaps does the C172 have?
6. Describe the C172 landing gear.
7. Describe the differences between early and late model electrical systems.

8. Describe the ignition system.
9. What type of stall warning system does the C172 have?
10. (True / False) There are different checklists for early and late model C172s.
11. Describe the differences between early and late model fuel systems.
12. By memory, be able to recite and write down all of the profiles contained in this supplement and on the C172 Maneuver Guide.
13. What is the first step in accomplishing a good landing?
14. Whenever possible, what distance should the traffic pattern be flown in a single-engine airplane?
15. For training and testing purposes, what speed should the airplane be flown on short final when landing is assured?
16. What is the typical approximate altitude above the landing surface to begin the roundout (flare)?
17. At what speed should the touchdown occur in a 172?
18. Define "managing energy".
19. After landing, how long should the centerline be maintained?
20. After touchdown, what should be done with the aileron controls as the airplane slows? Why?
21. What information should a visual approach briefing include?
22. What does an approach briefing accomplish?
23. Be able to articulate an example visual approach and landing briefing using the example provided in the Supplement.
24. Define stabilized approach according to the Airplane Flying Handbook.
25. What are the general conditions for a stabilized approach?
26. What should a pilot do if the general conditions for a stabilized approach don't exist during an approach? What if an instructor is on board?
27. What is, in your opinion, the most important part of a stabilized approach?
28. What action should be taken if a pilot at 1,000' AGL maintaining a constant angle glidepath is 10 knots too fast?
29. While maintaining a stabilized approach, what control input should the pilot use to correct for airspeed deviations, change the pitch or change the power?
30. Define "aiming point" according to the airplane flying handbook.

31. While maintaining a stabilized approach, what control input should the pilot use to correct for the aiming point moving up in the windshield, change the pitch or change the power?
32. If the aiming point is moving up in the windshield, is the airplane moving lower or higher reference the constant angle glidepath?
33. What does it mean if a pilot flying in level flight has to physically keep the airplane from climbing by applying forward pressure on the yoke?
34. What does it mean if a pilot flying in level flight has to physically keep the airplane from descending by applying aft pressure on the yoke?
35. According to Cessna, what is the best flap setting for a normal landing a C172?
36. How should the approach speed be adjusted for gusty winds?
37. Calculate the correct approach speed until short final given the following conditions.
 - Flaps 20°
 - Winds 240 @ 8, gusting to 18
38. Why is correctly adjusting the seat position before each flight important?
39. When should the pilot get ATIS, brief the approach, and complete the Approach Checklist?
40. Are the power settings listed on the landing profiles exact or approximate?
41. Is the aiming point also the touchdown point? If not, what is the difference?
42. What is the maximum recommended flap setting for crosswinds?
43. Does ATP recommend the crab method or wing-low sideslip method during a crosswind approach and landing?
44. When using the wing-low sideslip technique, will left or right rudder be required during a strong right crosswind?
45. Which control surface, aileron or rudder, corrects for wind drift during a crosswind landing?
46. During crosswind landings, which control surface, aileron or rudder longitudinally aligns the airplane with the runway centerline?
47. What is the max demonstrated crosswind in the C172?

48. When flying the downwind leg with a strong tailwind, where should the turn to base be started?
 - At the 45° angle to the intended touchdown point
 - Plan the turn early so the base leg can be flown at the appropriate distance from the runway
 - Plan the turn late so the base leg can be flown at the appropriate distance from the runway
49. What control inputs, if any, should the pilot apply after the airplane touches down?
50. What is the difference between a go-around/missed approach and a rejected landing?
51. During an ILS approach, when is the airplane considered established inbound?



PilotPool.com

Maximize the value of your training at ATP with exclusive access to get in front of airline recruiters.

FREE for ATP Graduates

- Get a FREE pilot profile with helpful pre-loading of ATP flight time
- Target the specific airlines you want to fly for
- Compare your ranking and project when you'll meet minimums

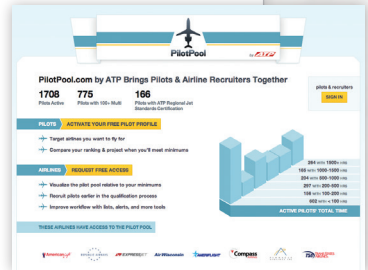

Whether you're airline qualified or working towards it, PilotPool.com will get you in front of airline recruiters. This is the first pilot recruitment tool of its kind. We allow airlines to visualize the pilot training pipeline, predict pilot supply, and begin recruitment earlier in your qualification process. With ATP's Regional Jet programs, you gain advanced ranking over pilots without it.

These Airlines Have Access to PilotPool.com



ATP FLIGHT SCHOOL.com
800-ALL-ATPS

800-255-2877 • info@atpflightschool.com